

2

1

B

B

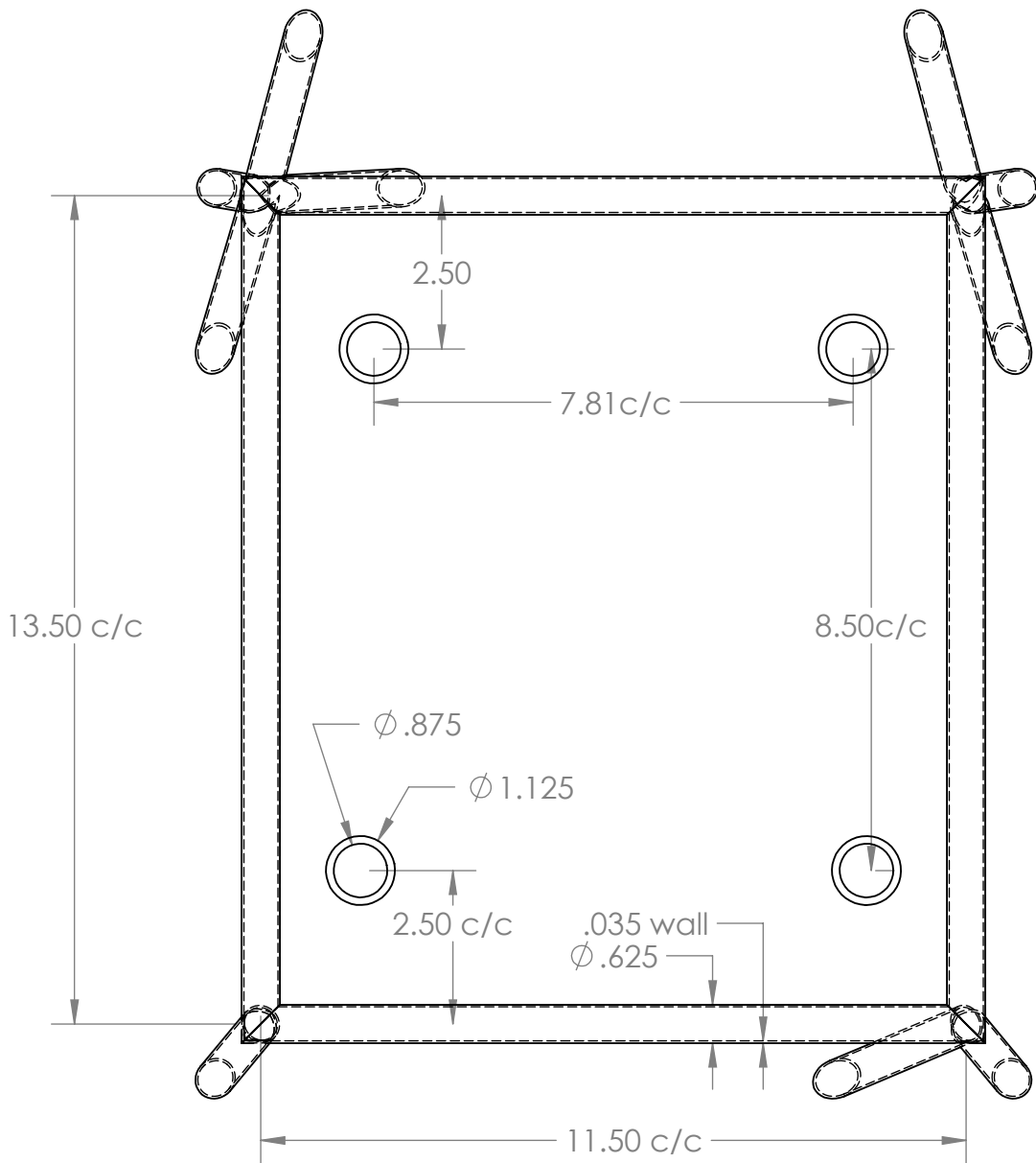

A

A

PROPRIETARY AND CONFIDENTIAL
 THE INFORMATION CONTAINED IN THIS DRAWING IS THE SOLE PROPERTY OF <COMPANY NAME>. ANY REPRODUCTION IN PART OR AS A WHOLE WITHOUT THE WRITTEN PERMISSION OF <COMPANY NAME> IS PROHIBITED.

		DIMENSIONS ARE IN INCHES TOLERANCES: FRACTIONAL ± ANGULAR: MACH ± BEND ± TWO PLACE DECIMAL ± THREE PLACE DECIMAL ±		NAME	DATE	<i>by Iron Design L.L.C.</i>	
		MATERIAL		DRAWN	sw		
		FINISH		CHECKED		front motor mount bushings front motor mount view	
NEXT ASSY	USED ON	APPLICATION		ENG APPR.			
		DO NOT SCALE DRAWING		MFG APPR.			
				COMMENTS:		SIZE DWG. NO. REV.	
				center to center marked by c/c		A	
						SCALE:1:3	WEIGHT: SHEET 1 OF 1

2

1