

# Engelman Engineering LE Landing Gear Springs Specifications

## AN Blue Aluminum Pipe Plug #806

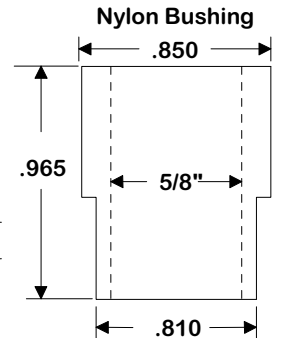
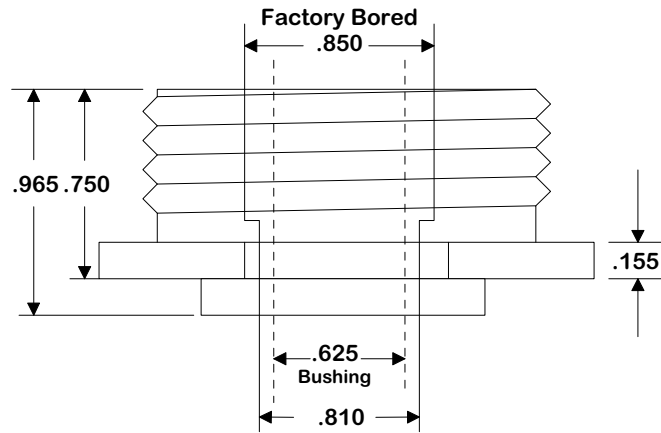
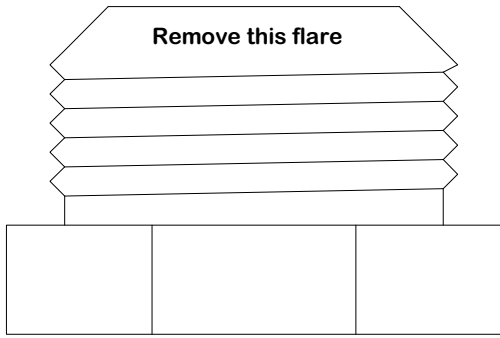

Nylon bushing should press fit into aluminum plug and must allow slider to move in and out freely.

## AN Black Steel Fitting #818

Gets turned off

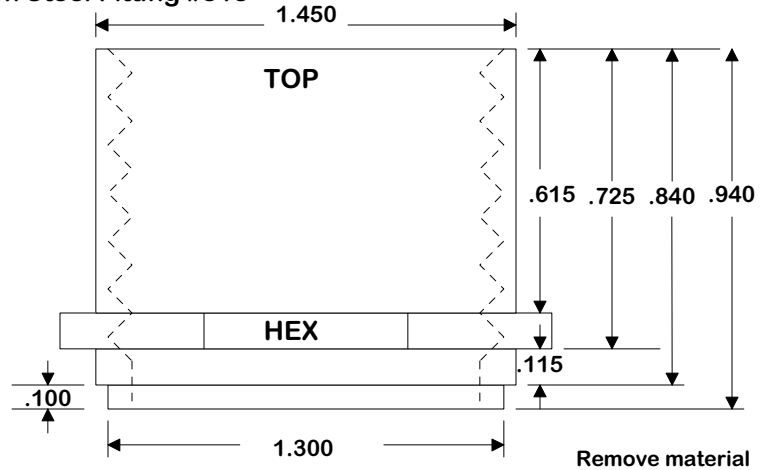
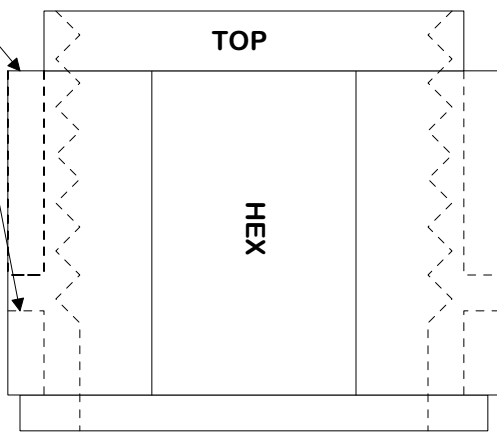

Remove material from bottom

Weld a solid slug approx 3/4" into the end of the 1/2" tube and then round off. Cap off the slug and tube with .040 strap and weld in place.

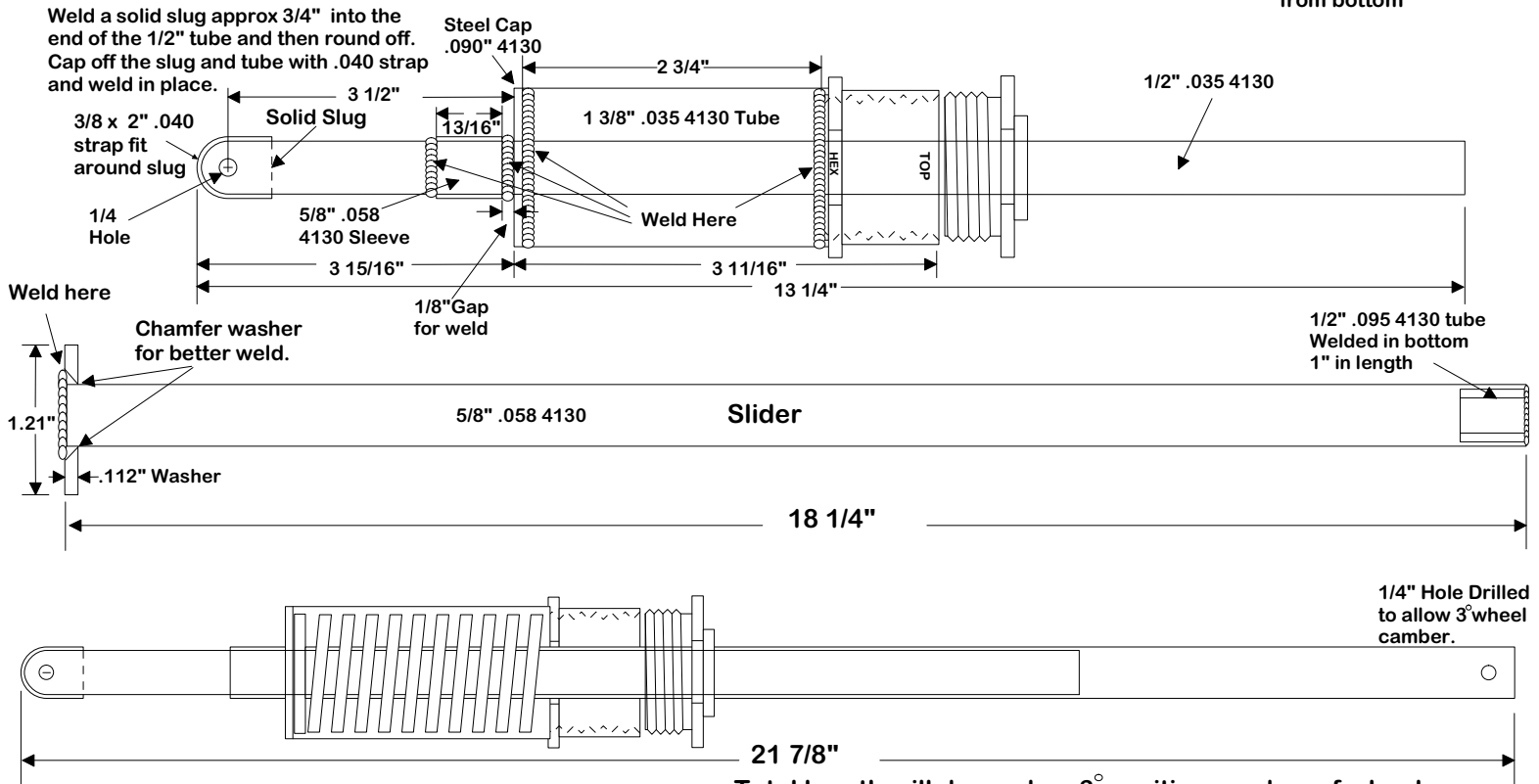

Spring is a McMaster Carr Part # 9295K69  
Spring must be ground to 1.225" O.D. to fit inside 1 3/8" tube.

Total length will depend on 3° positive camber of wheels. Camber is measured with fuselage level and suspended off of the ground without any load. If after loading suspension, wheel camber goes negative, shim springs with 1/16" washers until positive.

